

ISIMET

S – Series Enclosure

Installation, Maintenance and Operation Instructions



The S Series Enclosures are pre-assembled enclosures intended for use with the *ISIMET* Utility Controller. The installation and mounting procedures described in this manual are intended as a reference guide for recommended techniques. This manual is not intended to prevent alternative means of installation of the unit where specific engineered design criteria mandates alternate methods of installation.

ISIMET

S – Series Enclosure
Installation, Maintenance and Operations Instructions

Copyright © 2015 *ISIMET/MAPA, LLC*.
All rights reserved.

This document is copyrighted. This document may not, in whole or part, be copied, duplicated, reproduced, translated, electronically stored, or reduced to machine readable form without prior written consent from *ISIMET*.

Although the material contained herein has been carefully reviewed, *ISIMET* does not warrant it to be free of errors or omissions. *ISIMET* reserves the right to make corrections, updates, revisions, or changes to the information contained herein.

ISIMET is a trademark of *ISIMET/MAPA, LLC*, an affiliate of **WCM Industries, Inc.**

Warranty:

ISIMET will repair or replace any defective parts or workmanship of the product for a period of one year from date of installation. Solenoid valves carry a separate warranty. Refer to documentation provided with those units. Damage caused by incorrect installation or improper usage is not warranted. Failure to follow recommended installation, operation, and/or maintenance procedures may void product warranty. Recovery rights shall be limited to the total sum of the amounts paid for the product by the purchaser.

Limits of Liability:

ISIMET's liability shall be limited to costs of repair or replacement parts. The Laboratory Service Panel and Utility Controller Systems are not intended for usage other than those expressly described in the provided manuals for each product. *ISIMET* shall not be liable for damage or injury caused by the improper use of the product.

ISIMET does not warrant against or assume liability for failure of operation or lack of notification to secondary integrated monitoring systems. The system should be thoroughly tested and adjustments made at time of initial operation. Periodic testing should be conducted by the user to assure that all components function and operate according to specifications.

Care should be taken in the installation of this product. *ISIMET* shall not be liable for damage or injury caused from the improper installation of the product.

Warranty is Subject to Compliance with Specific Installation Requirements.

EXTENDED WARRANTY:

ISIMET will extend the warranty period of the products when installation complies with all start up procedures and that a factory authorized agent either performs or is in attendance during start-up of the system(s). Controllers, Companion and Accessory Panels will be extended to a period of five years from date of installation. Except for *ISIMET* FLA, DLA, RLA and other Units where automation systems are not common, Control System(s) must be interfaced with a building automation system or other *ISIMET* approved time sequencing control for “non-use” system shutdown. All operating components of the system must be *ISIMET* provided. Prescribed routine maintenance procedures must be performed per *ISIMET* recommendations.

All Start-up and Routine Maintenance Documentation shall be per Factory Recommendation.

Further, required start-up and maintenance procedures must be performed as directed upon all affected systems. This warranty shall only become enforceable upon issuance of application specific Extended Warranty Document. A copy of this document should be maintained at all times at the location of the warranted systems.

DISCLAIMER OF IMPLIED WARRANTY:

THERE ARE NO WARRANTIES THAT EXTEND BEYOND THE DESCRIPTION HEREIN. SELLER DISCLAIMS ANY IMPLIED WARRANTY OF MERCHANTABILITY OF THE GOODS OR OF THE FITNESS OF THE GOODS FOR ANY PURPOSE, AND BUYER AGREES THAT THE GOODS ARE SOLD “AS IS.”

Printed in the United States of America.

Table of Contents:

	<u>Page</u>
Warranty.....	2
Caution and Fuse Statements	3
Model Numbers.....	4
Enclosure Specifications.....	4
Enclosure Dimensions.....	5
Solenoid Valve Product Numbers.....	6
Solenoid Specifications & Wiring Information.....	7
Ball Valve Specifications.....	7
Inlet and Outlet Fitting Options.....	8
Parts List.....	8
Installing the Enclosure.....	9
Enclosure Piping Connection.....	10
Testing and Cleaning the Piping System.....	10
Special Arrangement and Placement of the Enclosure..	10
Removing and Re-installing Door Panel.....	11
Installing Door Trim.....	11
Routine Maintenance.....	12

Caution:

Pressure testing for fuel gas system solenoids should not exceed 15 psi at the body of this valve due to potential damage caused by excessive pressure applied to the diaphragm. Coils should not be energized unless secured to the valve core. Coils will heat during operation. A temperature of $\pm 150^{\circ}$ is not uncommon.

General Service Solenoids: Where adverse or harsh operating conditions exists in the water system such as the presence of hard water, then it is recommended that only Series 200 Solenoids with 12-VDC latching coils be utilized and that an extensive routine operating and maintenance program be developed by the end user to counter the effects of these conditions. Where operation of water containing corrosive agents, exotic or harsh mediums are intended for control by solenoid then verify application prior to installation. ISIMET cannot warrant against the effects of hard water, corrosive agents, contaminants, or debris present in the piping system or against effects of exotic or harsh substances. If specific operation conditions are in doubt, contact ISIMET prior to installation.

Wiring Information and Instructions:

Enclosures having 24 VAC and 120 VAC coil voltage where ISIMET provides control are provided with solenoid leads terminated at a multi-post terminal block. Enclosures having 12 VDC coils without 120 VAC provided in the Enclosure require an additional 12 VAC wire from the ISIMET control unit. Terminal posts are labeled to correspond with output circuits from a Utility Controller. Minimum wire sizing is 18 AWG.

Enclosures having 120 VAC coil voltage for use with a Utility Controller with 24 VAC control are provided with Model # RIBMN24S panel mounted relay within a J-Box at the top of the enclosure. Enclosures provided with 120-vac coils for other applications are provided J-Box with a contact input terminal. Solenoid leads are connected to a contact output terminal at each relay. Each relay is labeled to correspond with output circuits from the Utility Controller. A terminal block is provided in the Enclosure for field wiring to 120 VAC line voltage. Refer to schematic provided in the unit for units having 120 VAC coils with either control from other sources or 24 VAC control.

Caution: Only connect 24 VAC control wiring from Utility Controller output circuits to input terminal at relays where coils are 120 VAC & control is 24 VAC. Grounding: 120 VAC Enclosures should be grounded by terminating service ground wire to enclosure at grounding lug.

All local codes must be followed when installing this unit and connecting the conduit to the service panel and making wiring connections. Do not install wiring or cable for integrated systems, remote panic assemblies or other interface wiring within conduit for either 24-vac control or 120-vac line voltage. Each wiring system should be housed in independent conduit and not bundled with wiring for other systems.

Caution: Connect appropriate control wiring from Utility Controller output circuits to input posts at terminal. Where reset fuses are provided at control circuitry for solenoid, having the fuse tripped indicates a malfunction in the operation of the solenoid. Service the solenoid to determine cause of failure, correct problems immediately. Do not bypass reset fuses in circuit.

NOTE: Only qualified craftsmen licensed within the governing jurisdiction to perform the work associated with this installation should install and/or service this equipment.

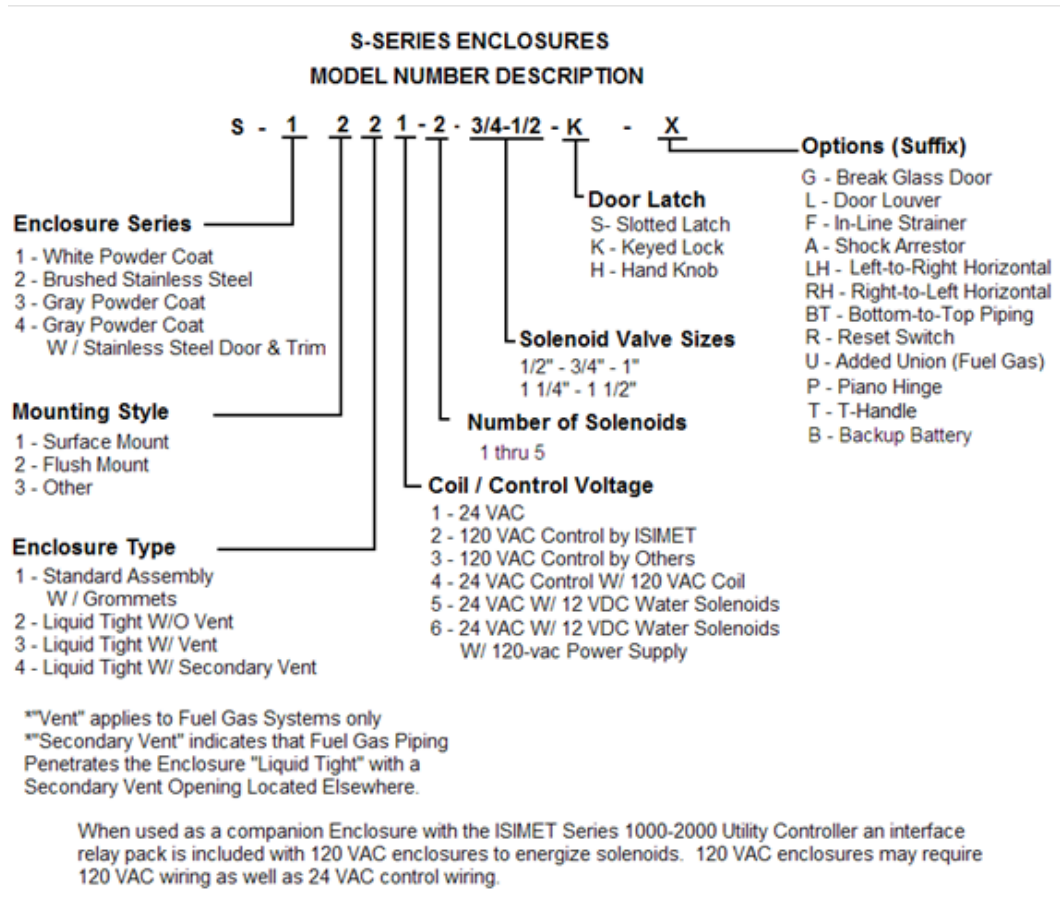

Enclosure Specifications and Dimensions:

The NEMA 1 enclosure may be surface or flush mounted. (Alternate mountings are described on page 10)

Door latch may be specified as either Screw Driver Latch, Hand Knob or Keyed Lock.

16X14, 18X18 & 24X24 Break Glass Door Models may also be specified.

The Four Types of the Enclosure are:

1. Standard Assembly - Enclosure is provided with rubber grommets for piping inlet and outlet holes.
2. Liquid Tight without Vent - Enclosure is provided with Liquid / Air Tight strain relief fittings for each inlet and outlet hole.
3. Liquid Tight with Vent - At each fluid controlled station, a Liquid / Air Tight strain relief fitting for each inlet and outlet hole is provided. At each gas controlled station lock nuts and sealant adhesive for each inlet and outlet hole are provided.
4. Liquid Tight W/ Secondary Vent - Provides the same air tight enclosure as type 3 except that the gas piping is provided with Air Tight strain relief fittings and a secondary penetration is provided with lock nuts for enclosure venting.
(Vent assembly permits the installer to connect containment piping as may be required by local ordinances. Attachment instructions are contained in the Installation Manual accompanying the enclosure.)

2, #3 and # 4 Rated Enclosures have an air/moisture tight rating similar to NEMA 4 and additionally are provided with an air-tight gasket at the door and adhesive and washers for all mounting hardware. Rating equivalence is based upon the installer's compliance with all installation instructions.

Valve assemblies "Stations" are arranged within the enclosure to insure ease in making field piping connections. Wiring leads for solenoids are terminated at contact points where interface relays are included. Each station is labeled for its intended use. i.e. "Nat. Gas"; "Cold Water".

Enclosure Dimensions for 1/2” – 3/4” Pipe:

Station #	1	2	3	4
Height	16	18	24	24
Width	14	18	24	30
Depth	6	6	8	8

Stations for General Service Enclosures W/ Strainers - Enclosure Height = 18 minimum
 Stations w/Strainers and (Shock Arrestors or Added Unions) -Enclosure Height =24 minimum

Enclosure Dimensions for 1” Pipe:

Station #	1	2	3	4
Height	18	18	24	24
Width	18	18	24	30
Depth	6	6	8	8

Stations for General Service Enclosures W/ Strainers - Enclosure Height = 24 minimum
 Stations W/Added Union and Strainers- Enclosure height = 24 minimum
 Stations W/ Strainers and Shock Arrestors- Enclosure height = 30 minimum

Enclosure Dimensions 1 1/4” – 1 1/2” Pipe:

Station #	1	2	3	4
Height	18	24	24	24
Width	18	24	30	36
Depth	6	8	8	8

Stations W/ Added Union - Enclosure height = 24 minimum
 Stations W/ Strainers – Enclosure height = 30 minimum
 Stations W/ Added Union and Strainers - Enclosure height = 30 minimum
 Stations 1 1/4” W/ Strainers and Shock Arrestors- Enclosure height = 30 minimum
 Stations 1 1/2” W/ Strainers and Shock Arrestors- Enclosure height = 36 minimum

Charts are based on top to bottom configuration.

Hot Water Return may add 6” in length of solenoid assembly and requires 8” spacing for 1” and smaller HWR.

16X14, 18X18 and 24X24 Enclosures are available in Break Glass Door.

Enclosures with added components or custom may be of larger size.

Depth dimensions are to face of enclosure, add approx. 3/4” for door panel.

Enclosures 24X36 and greater are provided with continuous hinge.

Custom assemblies due to wall cavity limitations are available in 24X24X6 enclosures.

Solenoid Specifications

ISIMET Model	Port Size (in)	Orifice Size (in)	Seat Material	Min. Pressure Diff.	Flow Factor Cv	Operation Pressure		24/60 VAC		120/60 VAC	
						Air/Gas psi	Water psi	VA Inrush	VA Holding	VA Inrush	VA Holding
S-101-SS	1/2	.5	NBR	0	4.8	230	230	25	14.5	25	14.5
S-102-SS	3/4	.75	NBR	0	9.8	230	230	25	14.5	25	14.5
S-103-SS	1	1	NBR	0	14	230	230	25	14.5	25	14.5
S-201	1/2	.5	NBR	2	4.8	230	230	25	14.5	25	14.5
S-202	3/4	.75	NBR	2	9.8	230	230	25	14.5	25	14.5
S-203	1	1	NBR	2	14	230	230	25	14.5	25	14.5
S-204	1 1/4	1.375	NBR	2	28	150	150	25	14.5	25	14.5
S-205	1 1/2	1.5	NBR	2	36	150	150	25	14.5	25	14.5
S-206	2	2	NBR	2	53	150	150	25	14.5	25	14.5
S-208	3	3	BUNA	3	77	225	225	-	-	45	27
S-222	3/4	3/4	FKM/NSF	2	9.8	230	230	25	14.5	25	14.5
S-223	1	1	FKM/NSF	2	14	230	230	25	14.5	25	14.5
S-224	1 1/4	1 3/8	FKM/NSF	2	28	150	150	25	14.5	25	14.5
S-225	1 1/2	1 1/2	FKM/NSF	2	36	150	150	25	14.5	25	14.5
S-301	1/2	.71	BUNA	0	4.0	3	171,600 *	45	27	45	27
S-302	3/4	.71	BUNA	0	4.9	3	241,500 *	45	27	45	27
S-303	1	1.26	BUNA	0	1.2	0.75	635,500 *	45	27	45	27
S-304	1 1/4	1.26	BUNA	0	14	0.75	762,700 *	45	27	45	27
S-305	1 1/2	1.89	BUNA	0.015	41	3	2,225,530 *	45	27	45	27
S-306	2	2.0	BUNA	0.015	50	3	2,732,994 *	45	27	45	27
S-308	3	3	NITRILE	0	93.6	1.5	5,188,000 *	-	-	113	113
S-401	1/2	.5	NBR	2	4.8	230	230	25	14	25	14
S-402	3/4	.75	NBR	2	9.8	230	230	25	14	25	14
S-403	1	1	NBR	2	14	230	230	25	14	25	14
S-501	1/2	.5	BUNA	3	4.2	225	225	12.9	8	-	-
S-502	3/4	.63	BUNA	3	6.4	225	225	12.9	8	-	-
S-503	1	1	BUNA	4.5	10.5	225	225	12.9	8	-	-
S-601	1/2	.625	NBR	0	2.8	TORR@.003	MERC @.00039	25	14.5	25	14.5
S-602	3/4	.625	NBR	0	2.8	TORR@.003	MERC @.00039	25	14.5	25	14.5
S-603	1	1	NBR	0	8.3	TORR@.003	MERC @.00039	25	14.5	25	14.5
S-605	1 1/2	1.89	BUNA	.15	41	TORR@.005	MERC @.00039	45	27	45	27
S-606	2	2.0	BUNA	.15	50	TORR@.005	MERC @.00039	45	27	45	27
S-702	3/4	.75	FKM	0	7	105	-	-	-	267	80
S-703	1	1.02	FKM	0	12	105	-	-	-	267	80
S-705	1 1/2	1.26	FKM	0	18	105	-	-	-	267	80
S-706	2	1.50	FKM	0	27	105	-	-	-	267	80
S-801	1/2	.55	FKM	0	3.1	105	105	57	23	57	23
S-802	3/4	.71	FKM	0	5.03	105	105	57	23	57	23
S-803	1	1.02	FKM	3	13	225	225	45	27	45	27
S-805	1 1/2	1.50	FKM	3	29	225	225	45	27	45	27
S-806	2	1.97	FKM	3	47	225	225	45	27	45	27
S-811	1/2	.55	BUNA	0	3.1	105	105	57	23	57	23
S-812	3/4	.71	BUNA	0	5.03	105	105	57	23	57	23
S-813	1	1.02	BUNA	3	13	225	225	45	27	45	27
S-815	1 1/2	1.50	BUNA	3	29	225	225	45	27	45	27
S-816	2	1.97	BUNA	3	47	225	225	45	27	45	27
S-822	3/4	.79	BUNA	3	5.9	225	225	45	27	45	27
S-823	1	1.02	BUNA	3	13	225	225	45	27	45	27
S-825	1 1/2	1.50	BUNA	3	29	225	225	45	27	45	27
S-826	2	1.97	BUNA	3	47	225	225	45	27	45	27
S-832	3/4	.79	PTFE	7.5	5.9	255	-	45	27	45	27
S-833	1	1.02	PTFE	7.5	13	255	-	45	27	45	27
S-835	1 1/2	1.5	PTFE	7.5	29	255	-	45	27	45	27
S-836	2	1.97	PTFE	7.5	47	255	-	45	27	45	27

- *BTU @ 0.60 Specific Gravity W/pressure drop of 0.5inch water column
- Vacuum is rated @ TORR and inches of Mercury
- For Stainless Steel – Refer to S100 & S-200 Series Specifications

Solenoid Valve Specifications:

Series 100-SS are Stainless Steel General Service NPT, Normally Closed 0 psi differential Solenoid Valve.

Series 200 are Brass General Service NPT, Normally Closed 2 psi differential Solenoid Valves.

Series 200-SS are Stainless Steel General Service NPT, Normally Closed 2 psi differential Solenoid Valve.
(Use 200-SS for lead free applications where lead free solenoids are not available.)

Series 220 are Lead Free Brass General Service NPT, Normally Closed 2 psi differential Solenoid Valves.
(Series 200 and 220 Solenoids are available W/ DC Latching Coils for use in Water Piping Systems)

Series 300 are Fuel gas, Aluminum construction Normally Closed Solenoid Valves.
(Designed for low pressure fuel gas applications.)

Series 400 are Brass General Service NPT, Normally Open 2 psi differential Solenoid Valves.
(Intended for use as Bypass Valves in Circulated Hot Water Systems.)

Series 500 are Brass General Service NPT, Low Wattage, Normally Closed 3– 4.5 psi differential Solenoid Valves.

Series 600 are Brass thru 1" & Aluminum 1 ½"-2" NPT, Normally Closed Solenoid Valves for Vacuum Systems.
(Suitable for Medium to Fine Vacuums only.)

Series 700 are Bronze NPT, Normally Closed Solenoid Valves for Fuel Oil Systems.

Series 800 are Brass NPT, Normally Closed Solenoid Valves for Oxygen, Acetylene, Argon, and CO2 Systems.

Series 810 are Brass NPT, Normally Closed Solenoid Valves for Hydrogen Systems.

Series 820 are Brass NPT, Normally Closed Solenoid Valves for Hi Pressure Gas Systems.

Series 830 are Brass NPT, Normally Closed Solenoid Valves for Helium Systems.

General Service Solenoids: Where adverse or harsh operating conditions exists in the water system such as the presence of hard water, then it is recommended that only Series 200 Solenoids with 12-VDC latching coils be utilized and that an extensive routine operating and maintenance program be developed by the end user to counter the effects of these conditions. Where operation of water containing corrosive agents, exotic or harsh mediums are intended for control by solenoid then verify application prior to installation. ISIMET cannot warrant against the effects of hard water, corrosive agents, contaminants, or debris present in the piping system or against effects of exotic or harsh substances. If specific operation conditions are in doubt, contact ISIMET prior to installation.

Maximum operating temperature for the solenoid is 180° F / 82.2° C

Coil Rating: Continuous duty totally encapsulated. Voltage Tolerances: +10%, - 10% of applicable voltage.

All Solenoid Standard Coils have a NEMA 1 Rating. Some valves are available as weather resistant and/or explosion proof.

DC Latching Coils are intended for use in applications where the presence of hard or corrosive water is anticipated to cause premature failure in the operation of the valve or where the ON operation of the solenoid is anticipated to extend for long periods without anticipated water flow. Where no 120 VAC wiring is provided at the unit then an additional control wire from the ISIMET control unit will be required to transmit the needed 12 VAC operating/control signal.

Ball Valve Specifications:

Apollo or Nibco Bronze 2-Piece Ball Valve. (or equivalent)

All valves are full port, bronze

Valve Station Suffix:

“TU” – General Service Threaded Union **150 psi SWP 600 psi CWP MSS SP-110**

“XU” – Non-Union **150 psi SWP 600 psi CWP MSS SP-110**

Valves for fuel gas systems are UL Listed but are not available with the integral output union (XU) only.

Valves greater than 2" only available in “XU”

Recommend the use of Series 220 for all domestic water systems.

1/2" & 2" Lead Free Solenoids are Currently Not Available. Recommend use of S-200-SS for these applications.

S-301 – S-304 & S-308 are 0 Differential; S-305 & S-306 are 0.015 psi Differential.

Caution should be used if S-305 and S-306 solenoids are used in science lab applications.

For domestic water systems, where minimum pressure differentials across the orifice prohibit the solenoid from functioning properly the Series S-100-SS solenoids should be utilized.

Inlet and Outlet Fittings Options: Inlet view shown – outlet similar

Inlet – Outlet Fittings: Two (2) sets of shown fittings for each station are provided with the enclosure dependent upon the style of enclosure specified.

Sealant/Adhesive should be applied around the attachment threads before insertion into the enclosure holes for all Liquid Tight and Liquid Tight with Vent Enclosures.

Connections to secondary containment piping should be connected to outlet end of vent fittings with interior ends left open.

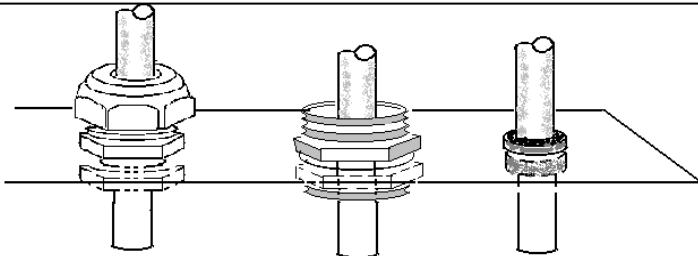

Liquid / Air - Tight
Strain Reliefs

Threaded Nipple W/
2 - Lock-nuts

Rubber Grommets
(Standard Assembly)

Enclosure Type – Bulkhead Fittings

Fittings and holes are as shown unless specifically ordered with alternate configuration.

Threaded nipple is field provided.

Inlet and Outlet Fittings for Enclosure

Inlet view shown - Outlet similar

Parts List:

1. IPS Service Cut-off Ball Valve
2. Solenoid Valve
3. Union
4. Pipe Nipple
5. Pipe Clamp
6. Aluminum Strut Support
7. Electrical J-Box (as required)
8. Enclosure
9. Inlet / Outlet Holes
10. Door Panel
(See Drawing Page 11)

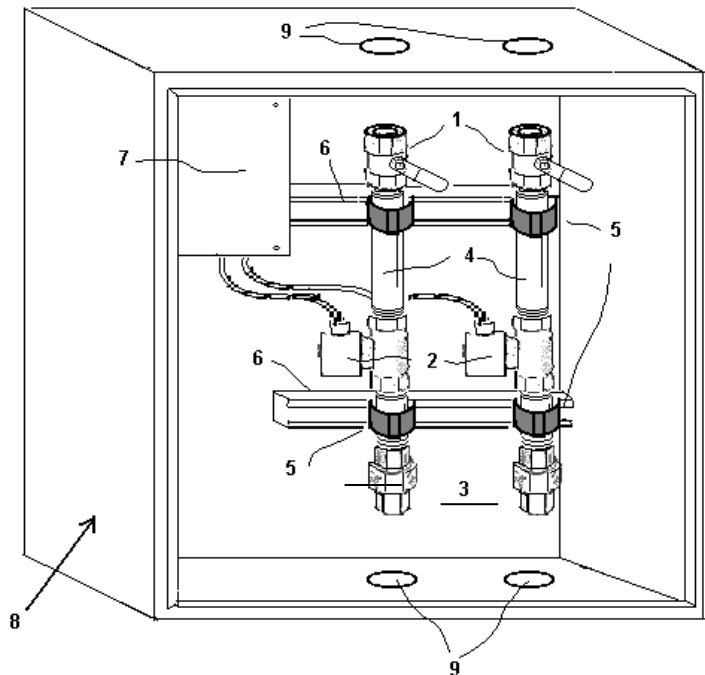

Parts List: (Optional components)

Refer to Product Specifications

11. Door Lock or Latch
 12. Flush Mount Trim
 13. Flush Mount Flanges (4 each)
 14. Surface Mounted Flanges (2 each)
 15. Liquid Tight Fitting *
 16. Lock nuts (4 per station)
 17. Grommets *
 18. Sealant / Adhesive (Provided only with Liquid / Air-tight Enclosures)
- * (2 per station as required)

Parts List: (Optional piping configurations)

Refer to Product Specifications

- Shock Arrestor with Brass Tee & fittings
- Brass Wye Strainer

All Natural Gas & LP assemblies are provided with Black Pipe Fittings and Style 300 Solenoids

All other assemblies use brass fittings.

Installing the Enclosure

There are two standard options for mounting the S-Series Enclosure: Flush Mounted and Surface Mounted.

CAUTION: Provided mounting hardware must be used.

Flush Mounted (typical)

Prior to installation:

- The S-Series Enclosure mounts between two standard spaced wall studs within a minimum 6" or 8" wall cavity. (See enclosure dimension – page 5)
- If stud spacing is greater than that required for the mounting of the controller, add studs to insure a secured mounting.
- The studs should be facing to facilitate securing the Enclosure.
- Predetermine wall finish so that the face lip of the enclosure aligns flush with the finished wall surface.

To install:

1. Using the self-starting screws (13), mount the flanges at each side and at the top and bottom of the enclosure.
2. Attach the enclosure to the wall studs with field-provided sheet metal screws per the drawing.
3. Level the enclosure.

Notes:

- When the Door Panel is mounted onto the Enclosure, it should protrude beyond the wall surface about 1/4". Care should be taken at installation time to ensure that this occurs.
- A Flush Mounting Trim Flange is provided with each flush mounted unit. Separate installation instructions and hardware are included with this flange.
- Flush Trim adds 3.5 inches to both Height and Width Wall Surface dimensions.
- It is the responsibility of the installer to verify finish wall dimensions.

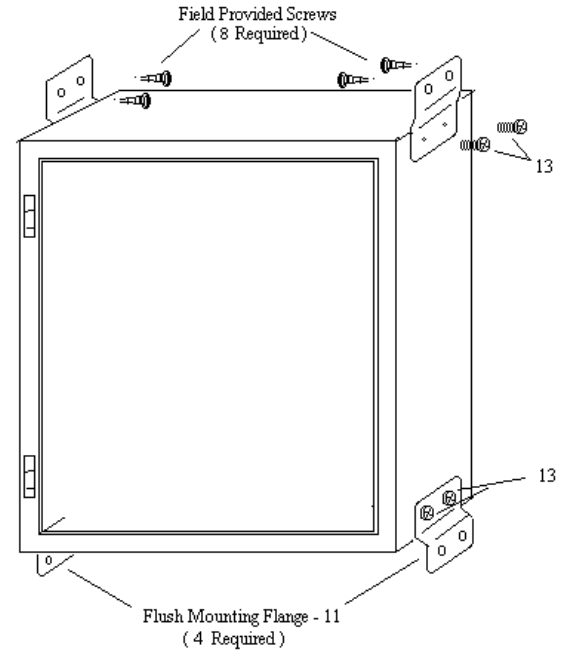

For best Flush Mounting results, recess face of enclosure's lip 1/2" behind wall finish

Semi-Recess Enclosure Placement Note: For Semi-Recess Units, the face of the enclosure's lip should be positioned 1/4" beyond wall finish.

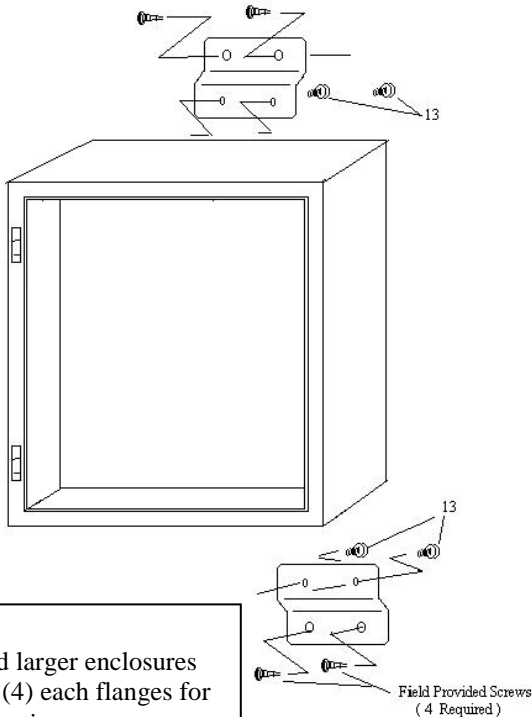

Note: 24 X 24 and larger enclosures utilize four (4) each flanges for surface mounting.

Clearance around Enclosure:
Care should be taken to allow 1/2" clearance from wall framing and sheet-rock or other wall surface material around the outer surface of the unit to permit the trim to be properly installed.

Surface Mounted (typical)

Prior to installation:

- Wall finishes should be complete.
- The wall cavity must have sufficient backing or support to ensure a firm mounting of the enclosure to the wall surface.

To install:

1. Secure the surface mount flanges to the back of the enclosure with the self-starting screws (13).
2. Use the field-provided screws to attach the enclosure by the flanges to the wall surface.
3. Level the enclosure.

Enclosure Piping Connections:

When making service piping connections, provide back-up restraint at the assembly so as to prevent the turning of the valve assemblies. Disrupting the factory piping connections may cause leakage.

The assemblies are mounted on aluminum strut using nylon pipe clamps in order to prevent harmonic hum from resonating through the corresponding piping systems and building structure.

Care should be taken for all Liquid Tight and Liquid Tight with Vent enclosures to assure that sealant/adhesive is applied at all penetrations and that connecting fittings are made liquid tight.

Testing & Cleaning the Piping System:

The piping system should be thoroughly tested and cleaned of all foreign matter and debris prior to placing the enclosure into service. Unions are provided loose fit. Inlets and outlets are plugged to prevent debris from entering the piping assembly.

The piping joints within the enclosure should be tested to assure tight connections. Do not exceed 15 psi test on any fuel gas system solenoid from upstream. Damage to the coil may result when first energized if testing is greater than 15 psi.

Caution: All local codes and regulations should be followed when installing the enclosure and making the piping connections.

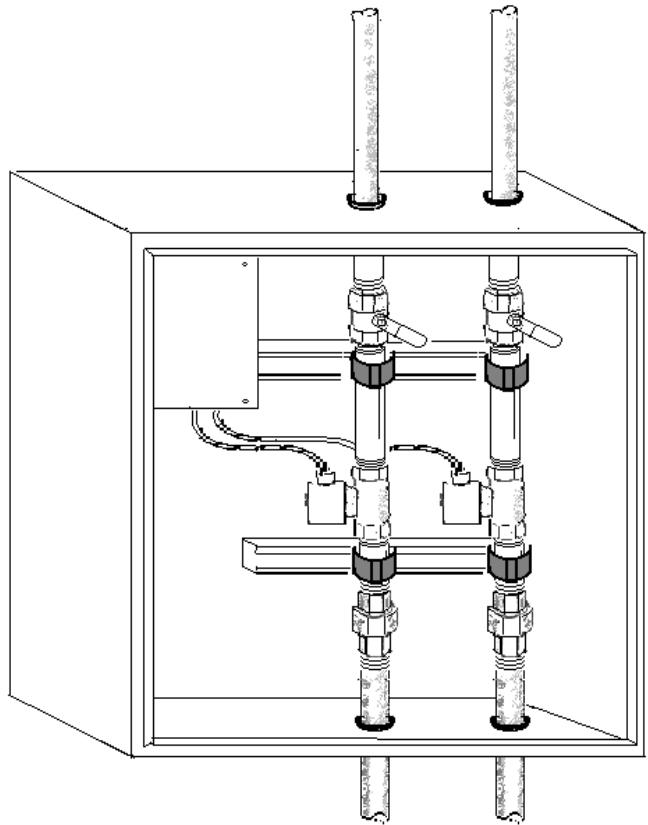

Special Placements and Arrangement of the Enclosure:

Were specified by the project design engineer, Enclosure may be suspended from structural members or elevated above floor surface. The use of industry standard support assemblies including threaded rod, strut channel and structural angle is recommended when supporting the enclosure by means other than described previously in this manual. *ISIMET* recommends that good industry practices be followed and that the support of the Enclosure and integral piping assemblies be separate from the support of the field installed piping systems. Do not support the enclosure directly from the connected piping. Installation should not inhibit access to the valve assemblies for the purpose of routine maintenance. The Enclosure should be mounted in a position and location whereby service to the assemblies can be rendered readily from a step ladder through ceiling access.

For convenience of the installation of the specific project requirements, the piping assemblies may be removed and reversed where in-line strainers are not present whereby the inlet of the system is at the base of the enclosure while the outlet is at the top. Solenoids should be turned to a horizontal or vertical position where coils are not inverted. Care should be taken in the removal and replacement of the assemblies to assure that wiring is not damaged or that the piping connections are not loosened. The S Series Enclosure can be custom fabricated so that the piping assemblies pass through both inlets and outlets thru the top or bottom of the enclosure. Solenoids should not be mounted in an inverted position.

Other arrangements not specifically stated herein are restricted unless certified in writing from *ISIMET*. Specifically, the enclosure and/or solenoid body cannot be mounted so that the solenoid coil rests in a downward or inclined position. Placing into operation a solenoid in this position may foul the diaphragm or orifice and prevent proper operation of the valve. Submit shop drawings or photographs in order to verify alternate installation techniques.

3" Solenoids **MUST** be mounted so that the coil rests in a full upright position.

Notice:

Piping system should be thoroughly flushed prior to operation. If systems are operated without proper flushing, the solenoid diaphragm may become fouled and may not close properly when solenoid coil is disengaged. ISIMET recommends providing in-line strainers immediately upstream of the solenoid for all fluid delivery systems, and where debris or harsh conditions are anticipated. ISIMET also recommends that shock arrestors be provided where water hammer is anticipated or when stated in the project specifications.

Removing and Re-installing the Door Panel

To install the Door Panel on the Enclosure:

1. Position the door at 90° – 100° of enclosure.
2. Slide top hinge pin onto fixed hinge post at top of door.
3. Slide lower hinge pin toward lower spring hinge mechanism with hinge pin lever in retract position.
4. With lower hinge pin in position, turn hinge pin lever outward and down, then turn inward to the extended lock position.

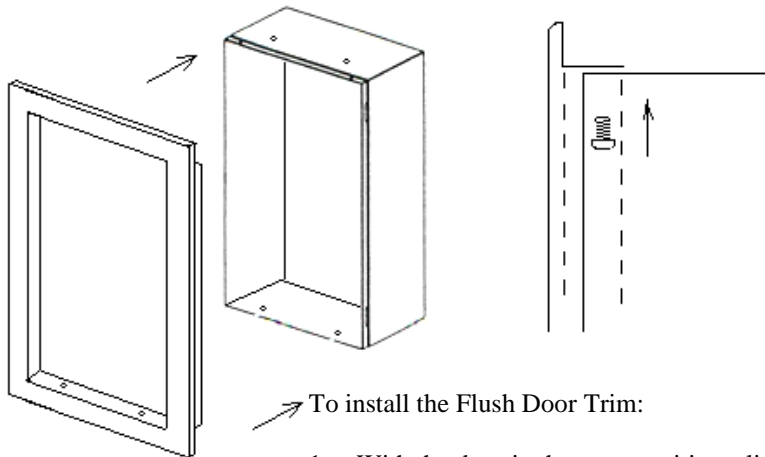
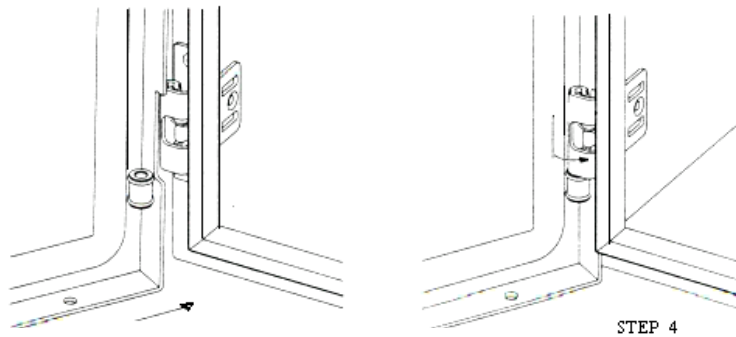
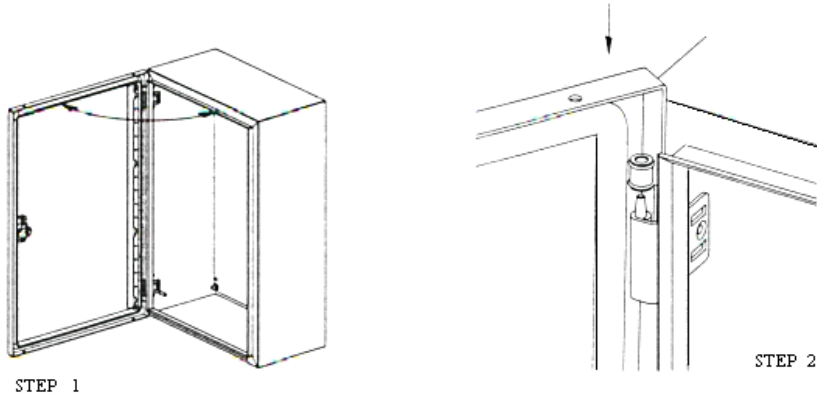

Installing the Flush Door Trim

Prior to installing Door Trim, ensure that wall finishes are complete and that the door panel has been installed.

→ To install the Flush Door Trim:

1. With the door in the open position, slide flush door trim over enclosure.
2. Align holes on enclosure with upper and lower holes in door trim.
3. Insert four (4) 12-24 (provided) screws through enclosure panel and tighten into door trim.

Note: Apply Sealant/Adhesive to trim screws at surface of Enclosure at each mounting hole for all Liquid Tight and Liquid Tight with Vent Enclosures.

Note regarding Door Panel and Trim: Enclosures with dimensions 24X36 and greater are provided with a piano hinged door mounted to the trim.

Routine Maintenance:

Periodic examination and testing of the piping system should be performed to assure that the solenoids are functioning properly and that no foreign debris has lodged in the solenoid valve orifice, preventing the proper operation of the valve.

CAUTION:

ISIMET DOES NOT recommend that service to emergency and/or safety devices, such as emergency showers and eyewashes, be controlled by the Utility Controller System or Solenoids. Such devices are intended to operate independent of restrictive authority operation as is the case with the design of this unit. **ISIMET** makes available components for the monitoring of such safety devices. Please contact **ISIMET** regarding any questions regarding this type of application. Power to the solenoids should be turned OFF when utilities are not in service.



ISIMET/MAPA, LLC

**103 W. CJ Wise Parkway
PO Box 129 (Mailing)
Naples, TX 75568**

**Phone (866) 897-0737
Fax (903) 897-0740**

www.ISIMET.com